

**catálogo oficial  
Norton audio**

**2011**

---

**Norton.**  
audio



ASYMMETRICAL  
LINE-SOURCE ARRAY | **ALS1**

---

**Norton**<sup>®</sup>  
audio

# ASYMMETRICAL LINE-SOURCE ARRAY | **ALS1**

The ALS1 is the factual illustration of the practical limits of modern state of the art.

By simply avoiding any mid-frequency horns, the ALS1 is just the most compact line source element presently available in their category.



The ALS1 ultra-efficient mid frequency drivers, do not involve any back or front chamber volumetric frames. Actually they directly profile the bass loudspeaker front band-pass cavity, allowing competent thermal freshening for themselves and an overall ultra-compact and extremely powerful packing that fills all the expectations about what a Line-Source should sound.

ALS1 is an active 3 way system with an operating frequency bandwidth from 60 Hz to 20 KHz. This response is lowered down to 28Hz with the addition of the SB118 or SB221 Subwoofers.

ALS1 features one 12" driver in a band-pass tuned Enclosure, two 6.5" back-sealed standalone medium drivers and two 1" ring-compression drivers coupled to our patented Elliptical Plane Progression isophasic Coupler (Eppic<sup>®</sup>) waveguide for HF reproduction.

The ALS1 comes complete with transport racks, rigging mechanics, power and control electronics.

Usable Bandwidth (- 10 dB): 60 Hz - 20 kHz  
Nominal Directivity (- 6 dB): 90° Horizontal - Symmetric  
Maximum Continuous SPL: 130 dB  
Power Handling: 1200 W

#### Components:

- LF: 1 x 12" weather-resistant 8 ohm
- MF: 2 x 6,5" weather-resistant
- 2 x 16 ohm
- HF: 2 x 1" HF Ring-Compression
- Driver 2 x 16 ohm

**Rigging:** Angles from 0° to 10° in 1° linear step increment

#### Physical Data:

- Width: 589,5 mm
- Height: 384 mm
- Depth: 444,2 mm
- Weight: 31 Kg
- Material: Baltic Birch Plywood
- Connections: 2 x 8 Pin Speakon

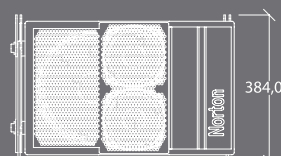
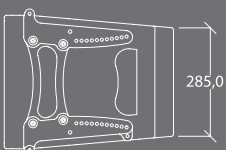
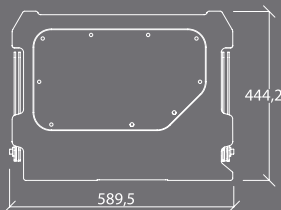



NORTON | **CF10**

**Norton**<sup>®</sup>  
audio

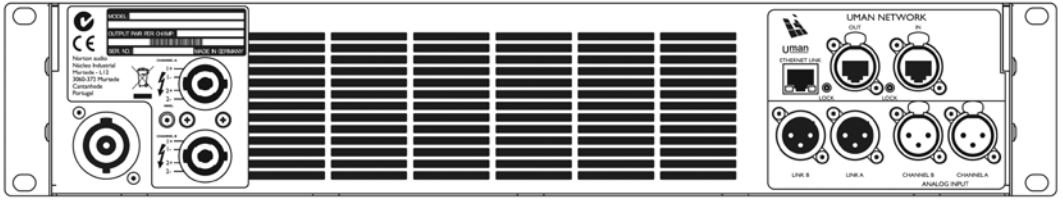

## Power

The NORTON® CF10 delivers 8600 Watts of pure power in 2 Ohm or 4 Ohm applications. You choose, same powerful result, a constant 4300 Watts of power per channel. The NORTON® CF10 offers levels of power and application flexibility truly suited to all worldwide pro-audio markets.

## No more Switches

A key part of the new NORTON® CF10 design is the absence of any control knobs or switches, front or back. Control of all parameters is via the screen user interface and gain slider. This clean, practical approach reduces wear & tear factors on moving parts while delivering a forward thinking approach to function, safety and plain good looks.

## UMANO Network Solution

UMANO network solutions, Any input – Any network – Any device. This advanced network solution is fitted as standard. UMANO is the next generation, a true network system for all. Super low latency – no problems with integration to existing technologies – no limitations.

## Intelligent Input Routing

The signal path is always optimal, no latency, a direct path from input to output bypassing any unnecessary A to D converts/ DSP. The network input is linked direct to the amplifier channel. You choose, run the system in full analogue or digital domains.

## DSP

An optional plug-in DSP card is available, allowing the NORTON® CF10 to become a fully DSP/DSP Network controlled speaker management system.

## Features

- 4400 Watts of peak power per channel in either 2 Ohm or 4 Ohm mode
- No external control knobs or switches
- UMANO network control
- Intelligent input routing
- Optional plug-in DSP card
- Dual Voltage SMPS with automatic selection for 120 v/230 v operation
- 3 Modes of operation: Dual Channel, Mono Bridge, Parallel-Mono

## Specifications

Dual Channel <sup>1)</sup>	8 Ω <sup>1)</sup>	2200 W
	4 Ω <sup>1)</sup>	3800 W
	2 Ω <sup>1)</sup>	4000 W
	Peak <sup>2)</sup>	4400 W
Mono	16 Ω <sup>3)</sup>	4400 W
	8 Ω <sup>3)</sup>	7600 W
	4 Ω <sup>3)</sup>	8000 W
	2 Ω <sup>4)</sup>	7600 W
	1 Ω <sup>4)</sup>	8000 W
Peak <sup>2)</sup>	8800 W	
Output Circuitry	Hybrid Class H	
Output Voltage	200 Vp/400 Vpp	
Frequency Response 8 Ω load, 1 dB below rated power	20 Hz - 20 kHz ± 0,15 dB	
Input Impedance	22 kΩ balanced	
Input Gain	selectable: 26 dB, 32 dB or 1,4 V input sensitivity	
Protection Circuits	inrush-current limitation, protection circuits against power on/off transients, temperature monitoring of transformers and heat-sinks, output DC protection, temperature dependent SOA protection, intelligent mains fuse protection	
Fan	2 temperature dependent speed-controlled axial fans	
LED Indicators	Signal & Clip for each channel	
Output Connectors	One 4-pole SPEAKON connector for each output channel (bi-amping possible)	
Modes Of Operation	DUAL CHANNEL, MONO BRIDGE and PARALLEL-MONO	
Options	Plug-in DSP card	
Signal To Noise-Ratio 20 Hz - 20 kHz, 8 Ω load	> 107 dB (unweighted) > 110 dB (A-weighted)	
THD+N (typical) 20 Hz - 20 kHz, 8 Ω load, 3 dB below rated power	< 0,01 %	
SMPTE (typical) 20 Hz - 20 kHz, 8 Ω load, 3 dB below rated power	< 0,01 %	
Damping Factor 8 Ω load, 1 kHz and below	> 400	
Net Weight	13,0 kg / 28,7 lbs	
Shipping Weight	15,6 kg / 34,4 lbs	
Dimensions (WxHxD)	483 x 88,9 x 453 mm / 19 x 3,5 x 17,8 inches (19', 2U)	
Shipping Dim. (WxHxD)	540 x 135 x 615 mm (0,045 m <sup>3</sup> ) / 21,3 x 5,3 x 24,2 inches	

<sup>1)</sup> All channels driven, 1 kHz, 1% THD @ 230 VAC, <sup>2)</sup> Peak Power, component tolerance dependent, <sup>3)</sup> Mono bridged, <sup>4)</sup> Parallel mono  
Subject to technical alterations without prior notice.



ELLIPTICAL PLANE  
PROGRESSION ISOPHASIC  
COUPLER | **EPPIC**<sup>®</sup>

---

**Norton**<sup>®</sup>  
audio

# ELLIPTICAL PLANE PROGRESSION ISOPHASIC COUPLER | **EPPIC®**



With a Patent granted in 2006, our Eppic® (\*) waveguide is one of the most advanced and innovative isophasic waveguides presently available.

The Eppic® design is based in a Family of Ellipses that starts on a circle (special case of ellipse) and stops in a line, defining the front-wave pathway inside the waveguide.

Eppic® is a decisive advance in the state of the art by their own remarkable simplicity. They have no twisting, mirrors, labyrinths, foam or anything able to perturb the natural sound radiation; only mathematically equal straight lines connecting the input waveguide circle to their output line.

Eppic® is an exemplary performer. As expected, their geometric cleanness has a very positive impact in the sound quality.

Despite its unusual warped aspect, their pathway is in fact shaped by diverging straight lines pierced into ellipses. Those geometric figures, however will be only observable when the construction is intentionally sliced in the correct planes.

The Eppic® is the heart acoustic technology around which the most of Norton Line-Source-Arrays are constructed.

(\*) Elliptical plane progression isophasic coupler

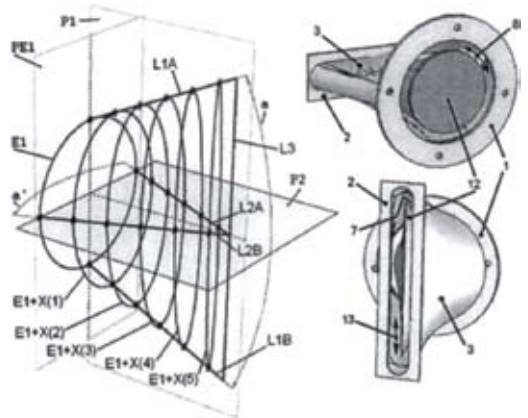



LINE-SOURCE  
ARRAY | **LS2**

---

**Norton**<sup>®</sup>  
audio

# LINE-SOURCE ARRAY | LS2

The LS2 element is a very compact and extremely powerful high output module that exceeds all the expectations about what a Line-Source should sound.

It is an active 2-way system with a operating frequency bandwidth from 80Hz to 20Khz. This response is lowered down to 28Hz with the addition of the SB118 or SB221 Subwoofers.

LS2 features Two 8" drivers in a bass-reflex tuned enclosure and a 1.5" compression driver coupled to our patented Elliptic Plane Progression isophasic Coupler (Eppic®) waveguide for HF reproduction.

The coplanar transducer configuration generates a symmetric horizontal coverage of 100° without secondary lobes over the entire frequency range. The 4-point rigging system is fully integrated into the LS2 cabinet allowing up to 24 elements to be flown in accordance with manufacture's recommendations.

The LS2 comes pre-wired, complete with rigging mechanics, power and Control electronics and delivered in road cases.



Usable Bandwidth (- 10 dB): 85 Hz – 20 KHz  
Nominal Directivity (- 6 dB): 90° Horizontal - Symmetric  
Maximum Continuous SPL: 128 dB  
Power Handling: 650 W

#### Components:

- LF: 2 x 8" weather-resistant
- 2 x 16 ohm
- HF: 1 x 1,5" HF compression driver
- 16 ohm

**Rigging:** Angles from 0° to 10° in linear step increment

#### Physical Data:

- Width: 509 mm
- Height: 269 mm
- Depth: 401 mm
- Weight: 25 Kg
- Material: Baltic Birch Plywood
- Connections: 2 x 4 Pin Speakon

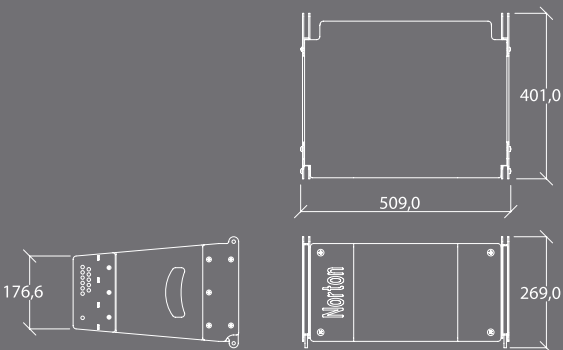



LINE-SOURCE  
ARRAY | **LS3**

**Norton**<sup>®</sup>  
audio

# LINE-SOURCE ARRAY | LS3



Exhibiting excellent amplitude and phase behavior, the LS3 Line-Source-Array element is one of the most linear in the industry while offering the simplicity of setup and operation provided by the accurate and straightforward mono-block rigging system and their very compact size.

The LS3 is an active 2-way system with an operating frequency bandwidth from 60 Hz to 20 KHz and this response is lowered down to 28Hz with the addition of the SB118 or SB221 Subwoofers.

LS3 features two 8" drivers in a bass-reflex tuned enclosure and a 1.5" compression driver coupled to our patented Elliptic Plane Progression isophasic Coupler (Eppic®) waveguide for superior performance HF reproduction.

The two front coplanar V-shaped transducers allow a great potential dynamic range, while aiding the HF waveguide to deliver a symmetric horizontal coverage of 90° without secondary lobes over the entire frequency range.

The LS3 comes pre-wired, complete with rigging mechanics, power and control electronics and delivered in road cases.

Usable Bandwidth (- 10 dB): 60 Hz - 20 kHz  
Nominal Directivity (- 6 dB): 90° Horizontal - Symmetric  
Maximum Continuous SPL: 128 dB  
Power Handling: 650 W RMS

#### Components:

- LF: 2 x 8" weather-resistant
- 2 x 16 ohm
- HF: 1 x 1,5" HF compression driver
- 16 ohm

**Rigging:** Angles from 0° to 10° in linear step increment

#### Physical Data:

- Width: 602 mm
- Height: 270 mm
- Depth: 499 mm
- Weight: 26 Kg
- Material: Baltic Birch Plywood
- Connections: 2 x 8 Pin Speak on

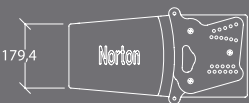
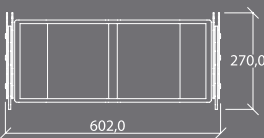
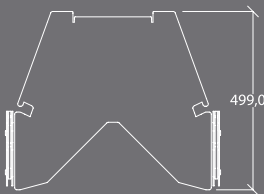

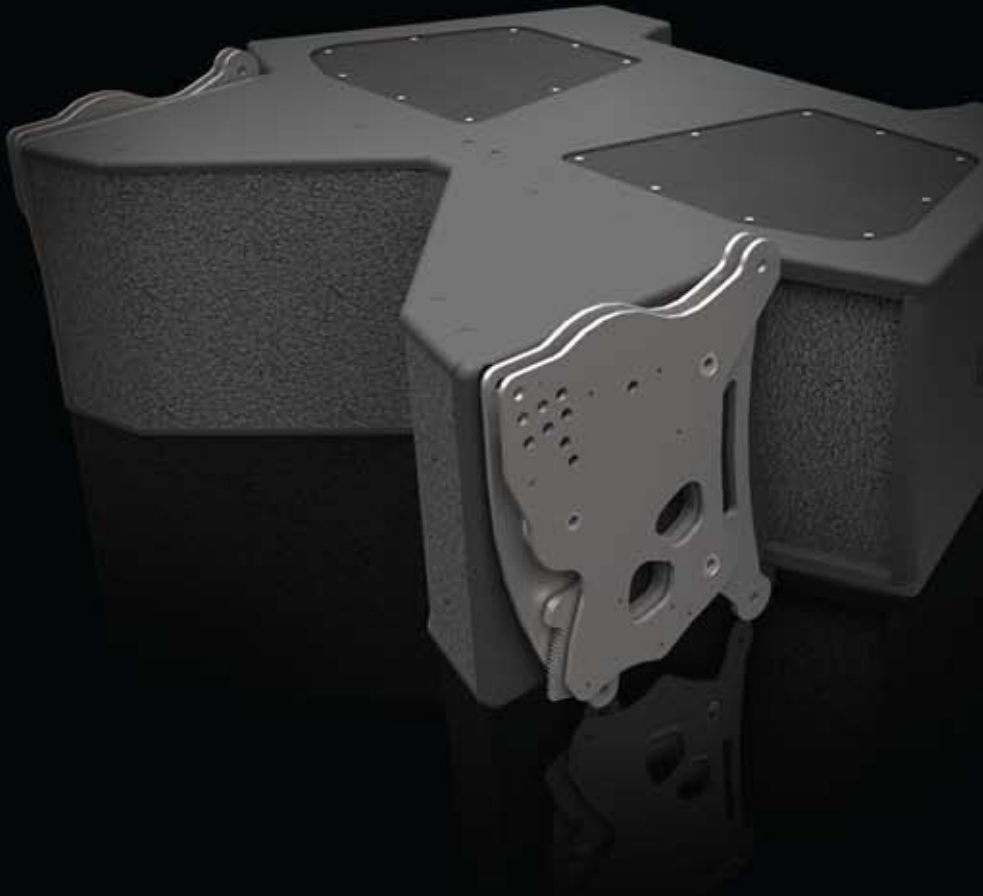

LINE-SOURCE  
ARRAY | **LS4**

---

**Norton**<sup>®</sup>  
audio

# LINE-SOURCE ARRAY | LS4



The LS4 element is a very compact and extremely powerful high-output module that exceeds all the expectations about what a Line-Source should sound. It is an active 3-way system with a operating frequency bandwidth from 60Hz to 20Khz. This response is lowered down to 28Hz with the addition of the SB118 or SB221 Subwoofers. LS4 features four 8" drivers in a bass-reflex tuned enclosure and a 1.5" compression driver coupled to our patented Elliptic Plane Progression isophasic Coupler (Eppic®) waveguide for HF reproduction.

The 8" drivers are fired in a way that all four are actually working in parallel at Low frequencies, providing the surface area equivalent to a 15" loudspeaker. At the Mid frequencies however, only the two front coplanar V-shaped transducers are working, aiding the HF waveguide to deliver a symmetric horizontal coverage of 90° without secondary lobes over the entire frequency range.

The LS4 comes pre-wired, complete with rigging mechanics, power and control electronics and delivered in road cases.

Usable Bandwidth (- 10 dB): 60 Hz - 20 kHz  
Nominal Directivity (- 6 dB): 90° Horizontal - Symmetric  
Maximum Continuous SPL: 130 dB  
Power Handling: 1300 W RMS

#### Components:

- LF: 4/4 x 8" (All 4 working)
- weather-resistance 2 x 16 ohm
- MF: 2/4 x 8" (Only front V-shaping)
- weather-resistance 2 x 16 ohm
- HF: 1 x 1,5" HF compression driver 16 ohm

**Rigging:** Angles from 0° to 5° in 0,25° linear step increment

#### Physical Data:

- Width: 756 mm
- Height: 270 mm
- Depth: 581 mm
- Weight: 36 Kg
- Material: Baltic Birch Plywood
- Connections: 2 x 8 Pin Speakon

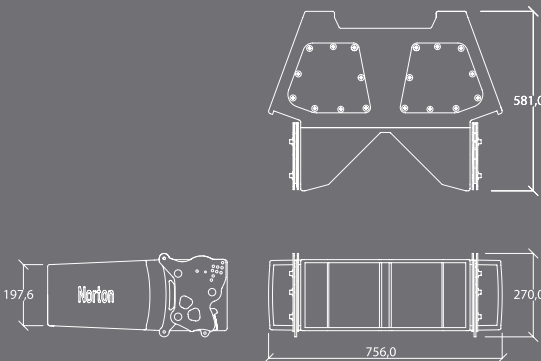



STAGE MONITOR | **M2**

---

**Norton**<sup>®</sup>  
audio

# STAGE MONITOR | M2



M2CX is a stand-alone coaxial two-way passive device with single Point-Source acoustic radiation in a very compact and low profile footprint. Designed for true "plug and play" operation, the passive crossover network uses elliptic topology with built-in phase compensation, real time compression driver protection and passive equalization.

M2CX is remarkable in its ability to achieve very high gain before feedback with little or no EQ. The technology used in their elliptic crossover/equalizer, provides an exceptional immunity to feedback, combining a neutral tone to a great intelligibility, even at high sound pressure levels.

The M2CX is a high performance stage monitor that doesn't necessarily need an external processor.

M2CX 2-way passive 8 Ohm design uses a single amplifier channel to deliver bi-amped performance for less space and complexity.

Usable Bandwidth (- 10 dB): 60 Hz – 20 KHz  
Nominal Directivity (- 6 dB): 90° Conical  
Maximum Continuous SPL: 128 dB  
Power Handling: 800 W

#### Components:

- LF: 1 x 15" Weather-resistant 8 ohm
- HF: 1 x 2" HF compression driver 8 ohm

#### Rigging:

- 6-M6 anchor points
- 1 flat Top hat
- 1 10° tilted Top hat

#### Physical Data:

- Width: 600 mm
- Height: 408,2 mm
- Depth: 540,8 mm
- Weight: 35 Kg
- Material: Baltic Birch Plywood
- Connections: 2 x 4 Pin Speakon

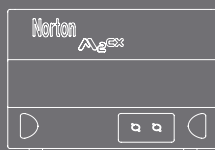
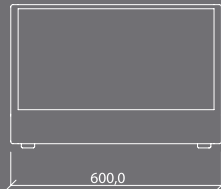
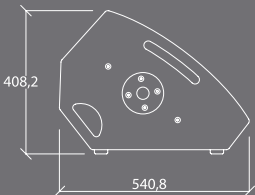

NORTON

STAGE MONITOR | **NF8**

---

**Norton**<sup>®</sup>  
audio

# STAGE MONITOR | NF8



With optimal vocal intelligibility and exceptionally regular response in frequency and time, NF8 is a stand-alone plug and play Coaxial two way passive device with single Point-Source acoustic radiation in a very compact and low profile footprint.

Containing a 1.5" silk-diaphragm driver coaxially loaded by an 8" low frequency loudspeaker in a bass-reflex tuned enclosure, the NF8 is a high fidelity and high output element that delivers incredible Spl from such a small enclosure.

The high-frequency driver is a remarkable device that incorporates the last and most innovative technologies, achieving a size so compact that allows it to be assembled at the exact 8" loudspeaker acoustic origin.

The NF8 loudspeaker, due to their small size, is also recommended in all situations in where it is mandatory an visually non-obstructive sound reinforcement system.

The NF8 will be very well accepted in where great sound quality and little space occupancy are a must.

Usable Bandwidth (- 10 dB): 85 Hz – 20 KHz  
Nominal Directivity (- 6 dB): 90° Conical  
SPL 1W/1m: 94 dB  
Maximum Continuous SPL: 118 dB  
Power: 300 W

#### Components:

- LF: 1 x 8" Weather-resistant 8 ohm
- HF: 1 x 1,5" HF Silk-diaphragm driver 8 ohm

**Rigging:** 6 points M6 T Nuts 1 Top hat

#### Physical Data:

- Width: 400 mm
- Height: 252,7 mm
- Depth: 310,9 mm
- Weight: 10 Kg
- Material: Baltic Birch Plywood
- Connections: 2 x 4 Pin Speakon

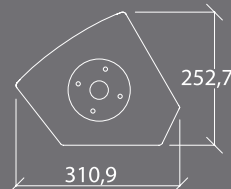
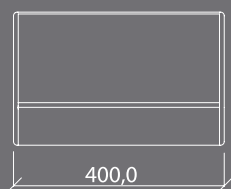



LOW SPEAKER | **NL4**

---

**Norton**<sup>®</sup>  
audio

# LOW SPEAKER | NL4



Usable Bandwidth ( - 10 dB ) : 40 Hz – 220 KHz  
SPL 1W/1m : 105 dB  
Power : 4000 W RMS

#### Components:

- LF : 4 x 18" Weather-resistant - 8 ohm

#### Physical Data:

- Width : 650 mm
- Height : 1200 mm
- Depth : 960 mm
- Weight: 106 Kg
- Suspensions Points : Optional - 4 Aeroquip System
- Material : Baltic Birch Plywood
- Connections : 2 x 4 Pin Speakon



Norton

Norton

Low Speaker | **P1 LOW**  
Point Source | **P1 TOP**

---

**Norton**<sup>®</sup>  
audio

# Low Speaker | P1 LOW

## Point Source | P1 TOP

The P1 System is designed in order that the Sound Engineer should feel free to focus his energy, talent and reactivity on the show itself. In order to that, the P1 system is self-sufficient, not requiring any special refinement or complex adjustments.

It is controlled by a dedicated processor, however the speaker is so linear by nature that there is no requirement to introduce correction of any kind, either phase or frequency.

P1 system is remarkable in their hocking simplicity of setup and operation. It is exceptional in their ability to start-up with superior sound quality right when fired up.

P1 system has excellent directivity characteristics. The sound is focused on the audience and a large proportion of the microphone/system interaction is reduced, providing more opportunity for gain without feedback.

The accessories include a transportation flight case witch is design to accommodate 3 speaker units with two configurations.

The most voluminous is designed to transport already assembled units with all of their suspension accessories. The assembly of a cluster is a very simple operation. One merely has to pull on the flight case cover, to fit a few accessories to it, and then lift the resulting assembly.

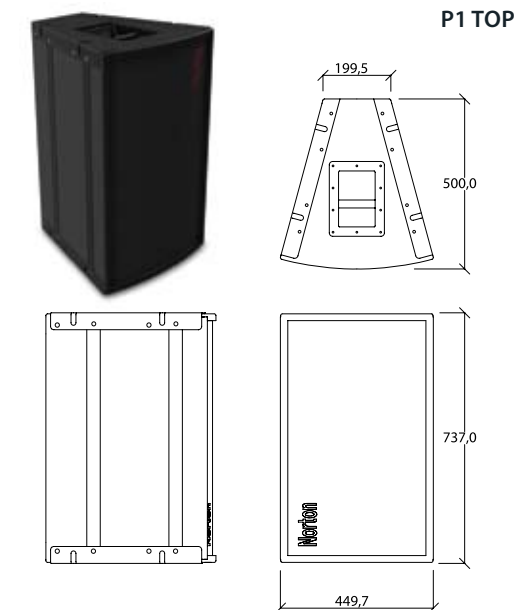
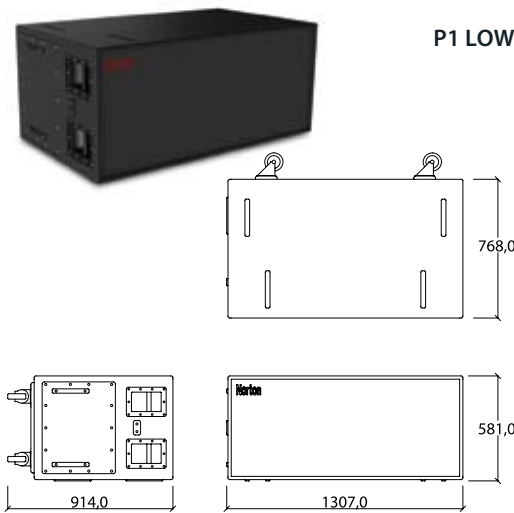



LOW SPEAKER | **SB112**

---

**Norton**<sup>®</sup>  
audio

# LOW SPEAKER | SB112

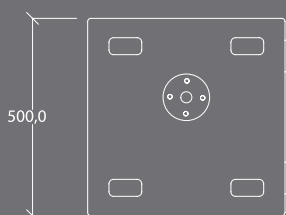

Usable Bandwidth ( - 10 dB ) : 32 Hz – 240 KHz  
Maximum Continuous SPL : 125 dB  
Power : 600 W RMS

#### Components:

- LF : 1 x 12" Weather-resistant - 8 ohm

#### Physical Data:

- Width : 507 mm
- Height : 367 mm
- Depth : 500 mm
- Weight : 26 Kg
- Material : Baltic Birch Plywood
- Connections : 2 x 4 Pin Speakon

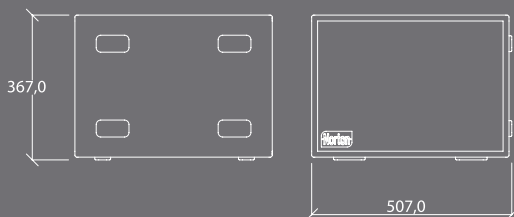



LOW SPEAKER | **SB118**

---

**Norton**<sup>®</sup>  
audio

# LOW SPEAKER | SB118

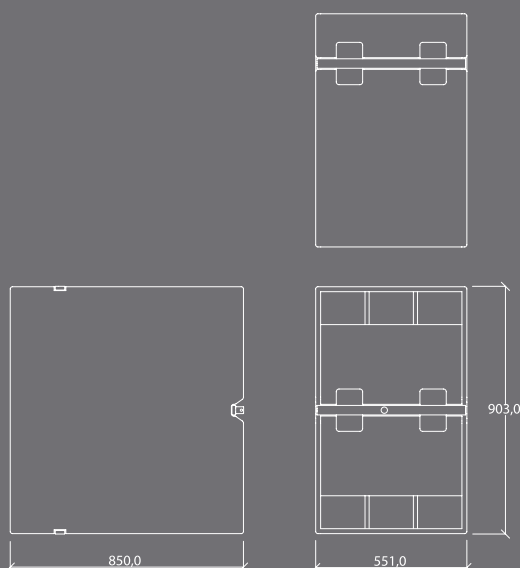

Usable Bandwidth ( - 10 dB ) : 28 Hz – 120 KHz  
SPL 1W/1m : 101 dB  
Maximum Continuous SPL : 130 dB  
Power : 1200 W RMS

#### Components:

• LF : 1 x 18" Weather-resistant - 8 ohm

#### Physical Data:

- Width : 903 mm
- Height : 551 mm
- Depth : 850 mm
- Weight: 77 Kg
- Suspensions Points : Optional - 3 Aeroquip System
- Material : Baltic Birch Plywood
- Connections : 2 x 4 Pin Speakon



INFRA SPEAKER | **SB221**

---

**Norton**<sup>®</sup>  
audio

# INFRA SPEAKER | SB221



Usable Bandwidth ( - 10 dB ) : 28 Hz – 120 KHz

SPL 1W/1m : 104 dB

Power : 3000 W RMS

#### Components:

- LF : 2 x 21" Weather-resistant - 4 ohm

#### Physical Data:

- Width : 1350 mm
- Height : 598 mm
- Depth : 900 mm
- Weight: 105 Kg
- Suspension Points : Optional - 4 Aeroquip System
- Material :Baltic Birch Plywood
- Connections :2 x 4 Pin Speakon

